

Sealing Air Leaks in Your Home

Housing Fact Sheet

What is Air Leakage?

Air leakage, or infiltration, is outside air that enters uncontrollably through cracks and openings in the walls, ceilings and floors of your home. Don't confuse infiltration with ventilation. Ventilation is fresh air that enters a house in a controlled manner to exhaust excess moisture and reduce odors and stuffiness. It is poor practice to rely on air leakage for ventilation. During cold or windy weather, too much air may enter the house and, during warm weather, too little. Also, a leaky house that allows moldy, dusty crawlspace or attic air to enter is not healthy.

The recommended strategy in both new and older homes is to reduce air leakage as much as possible and to provide controlled ventilation as needed. For simple house designs, effective spot ventilation, such as kitchen and bath fans that exhaust to the outside, may be adequate. For more complex houses or houses in very cold climates, whole house ventilation systems may be appropriate. Such systems may incorporate heat recovery, moisture control, or air filtering.

What Are the Benefits of Air Sealing?

Air infiltration can account for 30% or more of a home's heating and cooling costs and contribute to problems with moisture, noise, dust, and the entry of pollutants, insects, and rodents. Reducing infiltration can significantly cut annual heating and cooling costs, improve building durability, and create a healthier indoor environment. The size of heating and cooling equipment can also be decreased, saving additional dollars.

What is an Air Barrier?

The ceilings, walls and floors that separate the inside heated space from the outside unheated space form the air barrier and the insulation barrier for a house. These two barriers differ by the materials used.

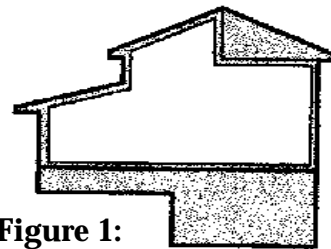

Figure 1: The ceiling, walls and floors between heated and unheated spaces form the air and insulation barriers of your home

For most homes, the sheet goods that form the ceiling, walls, and floor (such as drywall, wood sheathing, and floor decking) are effective at stopping air leakage. However, there are often cracks where walls meet floors and ceilings. This is especially true in older houses. Also, ceilings, walls, and floors have had holes cut into them during the construction process to provide access for wiring and piping. While the best time to plug these holes and cracks is during the initial construction of a house, this often is not done. So it is a good idea to spend some time looking for and sealing holes and seams with durable caulks, weatherstripping and foam sealant.

Most Insulation Products Do Not Block Air Flow

Certain types of insulation, such as dense-packed cellulose and certain foams, can be effective at reducing air flow as well as heat flow. But most homes are insulated with low density spun glass or cellulose insulation products¹. While these types of insulation products work well to block conductive heat loss (the flow of heat through solid materials) they do not work well to block convective heat loss (the flow of heat through a fluid substance-air or water). So any time heated indoor air or cold outdoor air comes into direct contact with your home's insulation, you will lose significant amounts of heat. This is why it is important to look for and plug cracks and holes in the heated and unheated side of walls, floors, and ceilings. This Fact Sheet will list the likely places in a home to look for such air leaks. It will also provide information about air sealing products and methods.

Diagnostic Tools

If you hire a contractor to seal air leaks in your home, be certain he/she has the proper diagnostic equipment to ensure that air sealing is done effectively. This requires the use of a blower door. A blower door consists of an adjustable panel and a powerful fan. The panel is fitted into the exterior door opening of the house. The fan pulls air out of the house and special equipment is used to measure the air pressure difference between indoors and outdoors. The tightness or leakiness of the house is determined by the pressure differences.

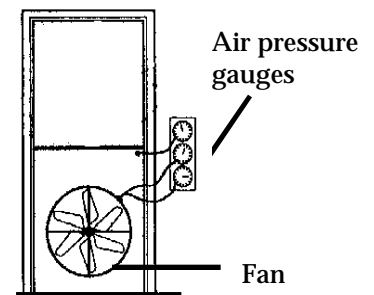

Blower Door

Can You Do The Work Yourself?

A very thorough and exhaustive search for all air leaks would require the services of an air sealing, insulation and home performance contractor. But most homeowners are capable of inspecting the attic and basement areas of their homes and sealing any holes and cracks located in those spaces. You don't have to find and plug every hole and crack to reduce your heating bill. Just plugging larger holes will save you money. If you do decide to hire a professional, be certain he/she has the appropriate diagnostic equipment to do a thorough job (see box).

¹For a thorough description of insulation products and materials see the Housing Fact Sheet, *Insulation Check-Up*, available from your local Cornell Cooperative Extension office.

What Are The Priorities For Air Sealing?

Although small cracks around windows and doors contribute to air leakage, the biggest holes are often located in the attic, crawlspace, or basement. Below is a list of areas in your house to check for air leaks.

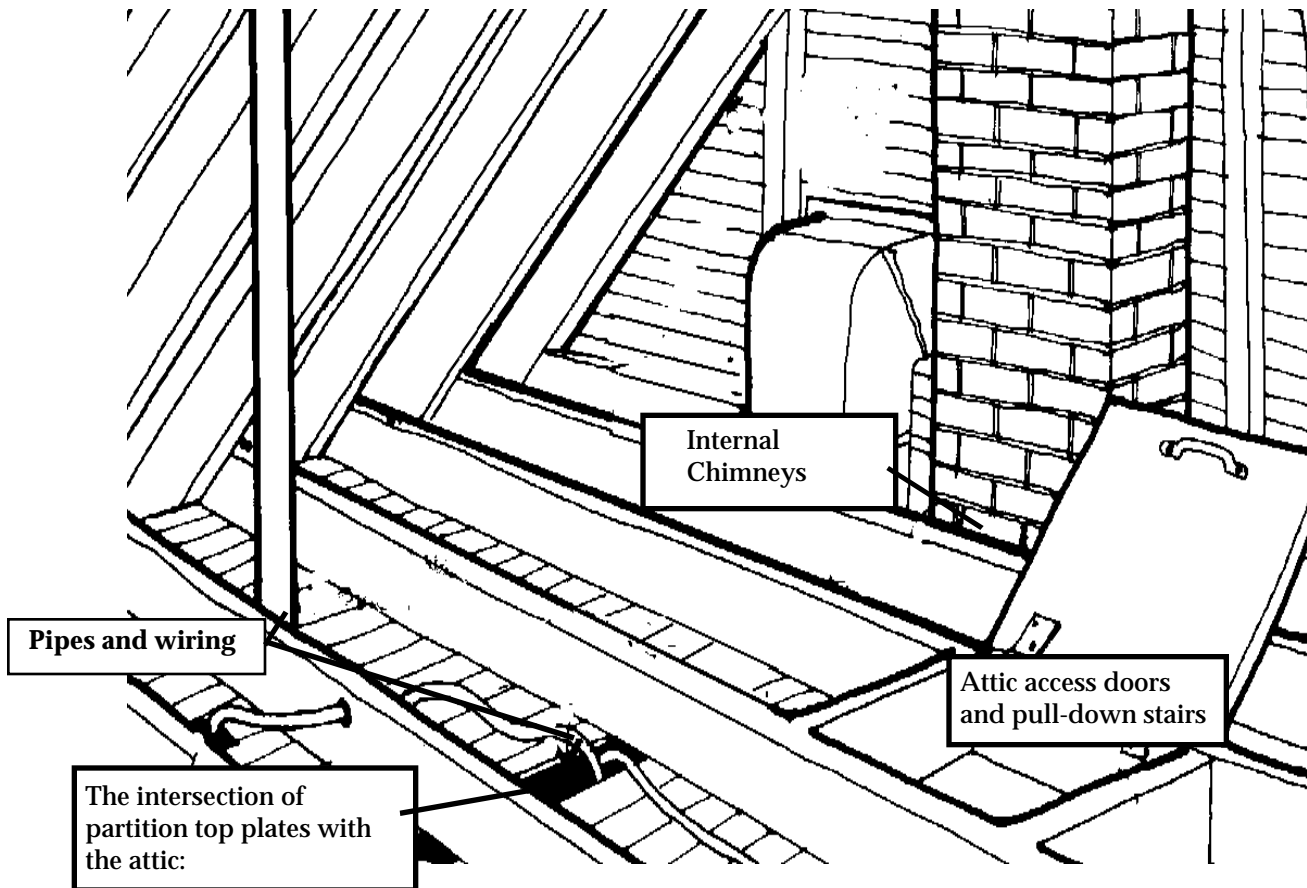

Figure 2:

What To Check in The Attic

Pipes and wires that extend through the ceiling

Bathrooms and kitchens typically have plumbing vent pipes that extend through the ceiling (usually these vent pipes are buried in a wall cavity so you can only see them in the attic). Seal gaps around pipes with backer rod (see box on page 8 for a description of various air sealing products).

Attic access doors and pull-down stairs

Make attic access doors and stairs airtight using latch bolts and weatherstripping. Add a rigid insulation layer to the back of access doors and add an insulated cover to the top of attic pull down stairs.

Internal Chimneys

This is another common source of air leaks into the attic. Most chimneys have open space around them because fire codes require that no combustible materials can be within 4" of a masonry chimney. Bridge gaps with sheet metal and fill bridged area with high temperature sealant.

Intersection of partition top plates with attic

If you want to do a very thorough job, check every inch of partition top plates and seal if needed. Even a gap of 1/16 inch along the top plate can allow significant amounts of heated air to escape into the unheated attic.

Other Attic Areas to Check

- **Kitchen Soffits (see Figure 3):**

The area above kitchen cabinets (often called the soffit or valance) is notorious for being a very leaky component in ranch style homes. The space enclosed by the soffit is often open to the attic and between the individual wall framing components. This lets heated indoor air escape to the attic and allows cold air from the unheated attic to enter the house. An easy method for air sealing this area is to stuff plastic bags with cellulose insulation, then stuff the bags in the appropriate areas (see Figure 3).

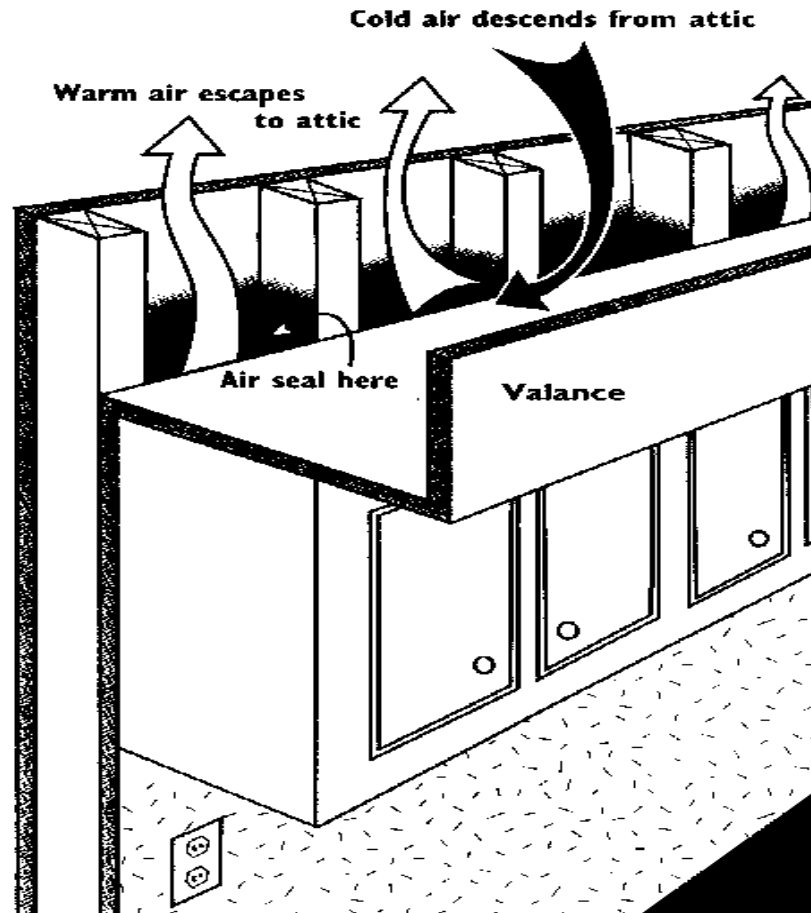

Figure 3: Kitchen Soffit

Source: *Home Energy*, May/June 1998, p. 19

As you can see from this diagram, the space enclosed by the valance is not easily accessible. Sometimes this space can be accessed from the attic. Gaining access may even require temporarily removing the valance board. If you are not comfortable with home repair projects, it is best to leave air sealing of these type spaces to the professionals.

Ceiling light fixtures

These are another common place where lots of warm air leaks from the house into the attic. If you have recessed lights that penetrate into an unheated attic, these penetrations are extremely leaky. **But be aware that you cannot safely air seal recessed light fixtures unless they are IC rated.** If your current recessed fixtures are not IC rated, consider having them replaced with UL-approved airtight IC rated recessed fixtures that meet ASTM-E283.¹

- **Whole house fan**

Use spray foam to seal around frame of whole house fan. Be careful not to block operation of louvers when you do this.

- **Attic to Knee-wall Transitions:**

Some houses have finished half attics. The knee-wall (the short wall between the attic floor and ceiling) often does not get air sealed during the construction process. Warm house air escapes through the unsealed floor joist cavities into the unheated space behind the kneewall. Seal these joist cavities with plastic bags stuffed with either cellulose or fiberglass insulation.

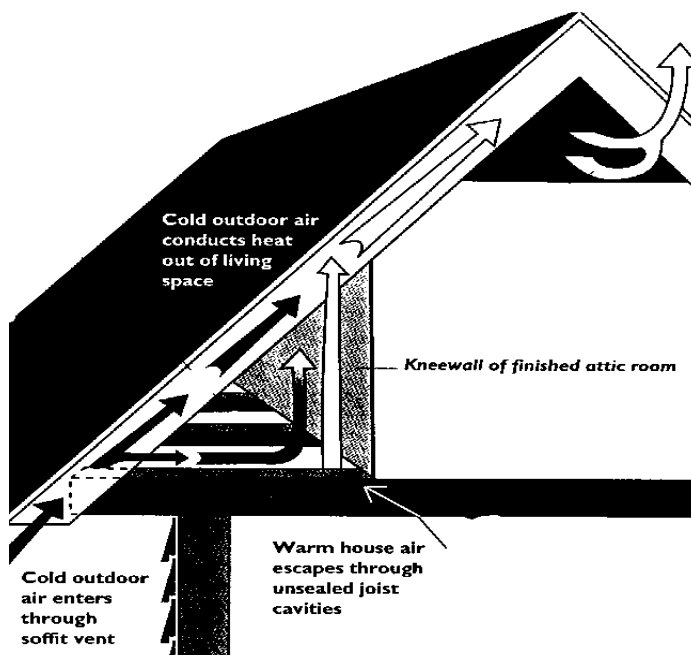

Figure 4:

Attic to knee wall transitions

Source: *Home Energy*; May/June 1998, p. 20

¹ASTM are the initials for the American Society for Testing and Materials. ASTM is a nonprofit international scientific and educational society that works to standardize specifications and methods of testing products and materials. When you see the ASTM initials on a product, it assures you that the product has been rigorously tested and found to perform as the manufacturer of that product claims.

Areas to Check Between the First Floor and Basement or Crawlspace

- **Areas where pipes and wires penetrate the floor**

Plumbers must cut a hole in the floor in order to install the bathtub drain. This hole seldom gets plugged during initial construction. Check the basement or crawlspace for plumbing and wiring penetrations. Seal holes with rigid insulation boards and spray foam.

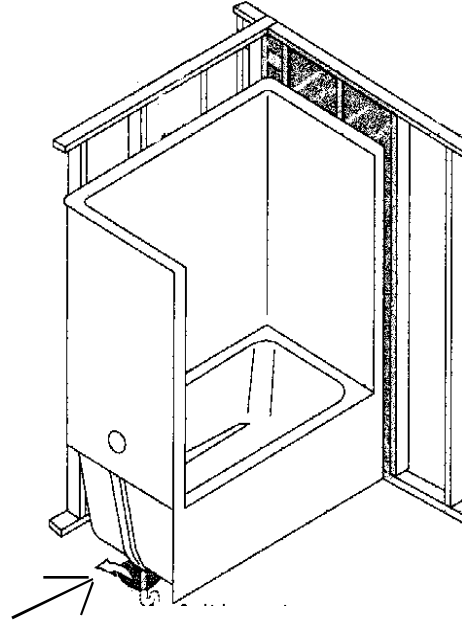

Figure 5

The hole cut in the floor to allow for installation of tub drain seldom gets sealed during construction.

- **Rim joist area (Figure 6)**

The rim joist often gets overlooked when houses are initially constructed. The rim joist should be sealed and insulated in both heated and unheated basements and crawl spaces. Cut pieces of rigid foam insulation to fit between the floor joists. Push the rigid insulation snugly against the rim joist and then seal the edges around the rigid insulation with spray foam. Access this area from the basement or crawlspace.

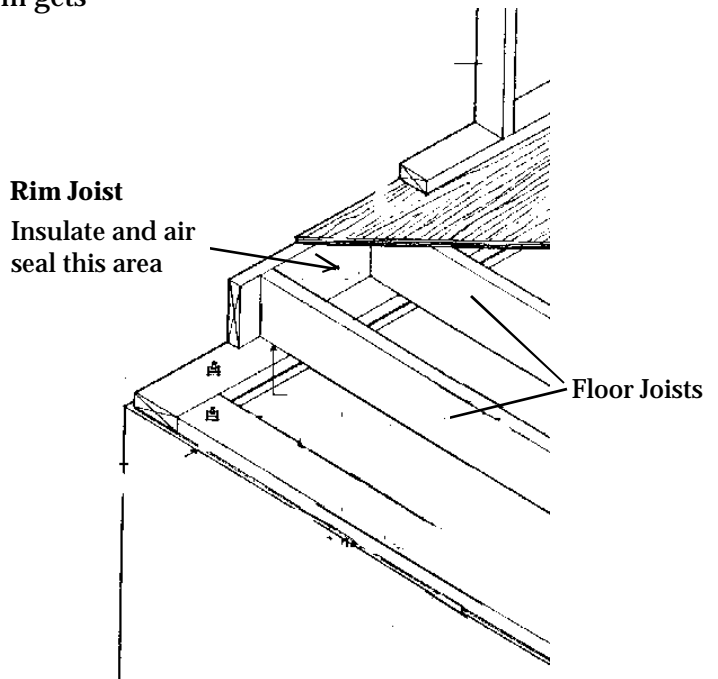

Figure 6:
Cut-away view of top of basement wall,
looking down from first floor

Other Areas To Check

- **Cantilevered Floors**

Some houses have cantilevered floors. This simply means that the floor sticks out past the supporting wall below. Figure 7 illustrates a correctly sealed cantilever. The space between the overhanging floor joists has been blocked off with pieces of wood. Unfortunately many homes with cantilevered floors have not had this blocking installed and sealed. If you have cantilevered floors in your home you should make certain they have been properly sealed and insulated. First floor cantilevers can usually be checked from the basement. Second floor cantilevers are more difficult to check. They require removal of the exterior soffit covering in order to view the area between the floor joists.

Figure 7: Cantilevered Floors

Correctly sealed cantilevered floor joists have the area between the joists sealed with wood or rigid insulation blocking. If that has not been done, tremendous amounts of warm air leak from the home.

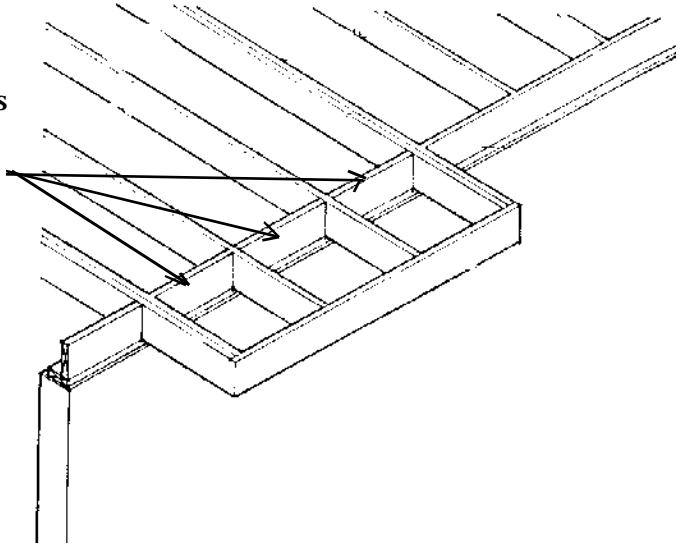

- **Electrical switches and plugs**

Remove switch and plug covers on a cold day and check for air infiltration by suspending a thread near the outlet opening. If air infiltration is evident install foam seals (Figure 8) behind the cover plates (plug and switch seals are available at most home improvement stores).

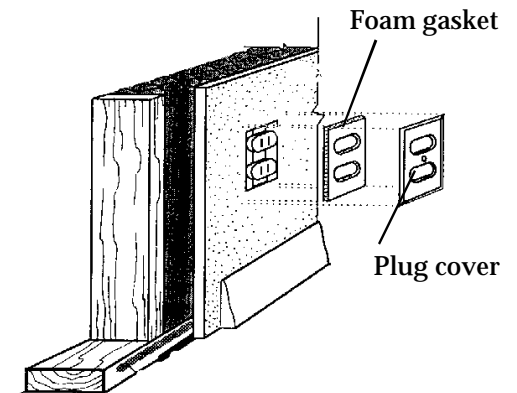

Figure 8:

Further Sources of Information:

United States Department of Energy Web Page:
www.eren.doe.gov/consumerinfo/heating.html

New York State Energy Research & Development
 Authority Web Page:
www.nyserda.org/

Lawrence Berkeley Laboratory Home Energy Saver
 On-Line Software:
<http://hes.lbl.gov/>

Fact Sheet: *Weatherstripping for Windows and Doors*
 Available from your local Cornell Cooperative Extension

Air Sealing Materials

Use a combination of these various air sealing products when plugging air leaks.

- **Caulk**
 Caulk works well to seal gaps of less than 1/2". Select grade (interior, exterior, high temperature) based on the application.
- **Spray foam**
 Spray foam fills large cracks and small holes. While polyurethane foams are very effective, they can be very messy and difficult to clean up. If you are working in an area where cleanup will be an issue consider using latex-based foams instead. **Do Not Use** near flames or near hot items (e.g., flue vents). **Do Not Use** expanding types of foam on windows and doors.
- **Backer Rod**
 This is closed-cell foam or rope caulk. Press into cracks with a screwdriver or putty knife. Often used with caulk around window and door openings.
- **Sheet Goods**
 Plywood, drywall, and rigid foam insulation can be used to seal larger openings. Foam can then be used to seal around edges.
- **Sheet Metal**
 Sheet metal can be used with high temperature caulk for sealing high temperature components, such as chimneys, to framing.
- **Weatherstripping**
 Weatherstripping is used to seal movable components, such as doors, windows and attic access panels.